

INSTRUCTION MANUAL

WAVE100i Mount

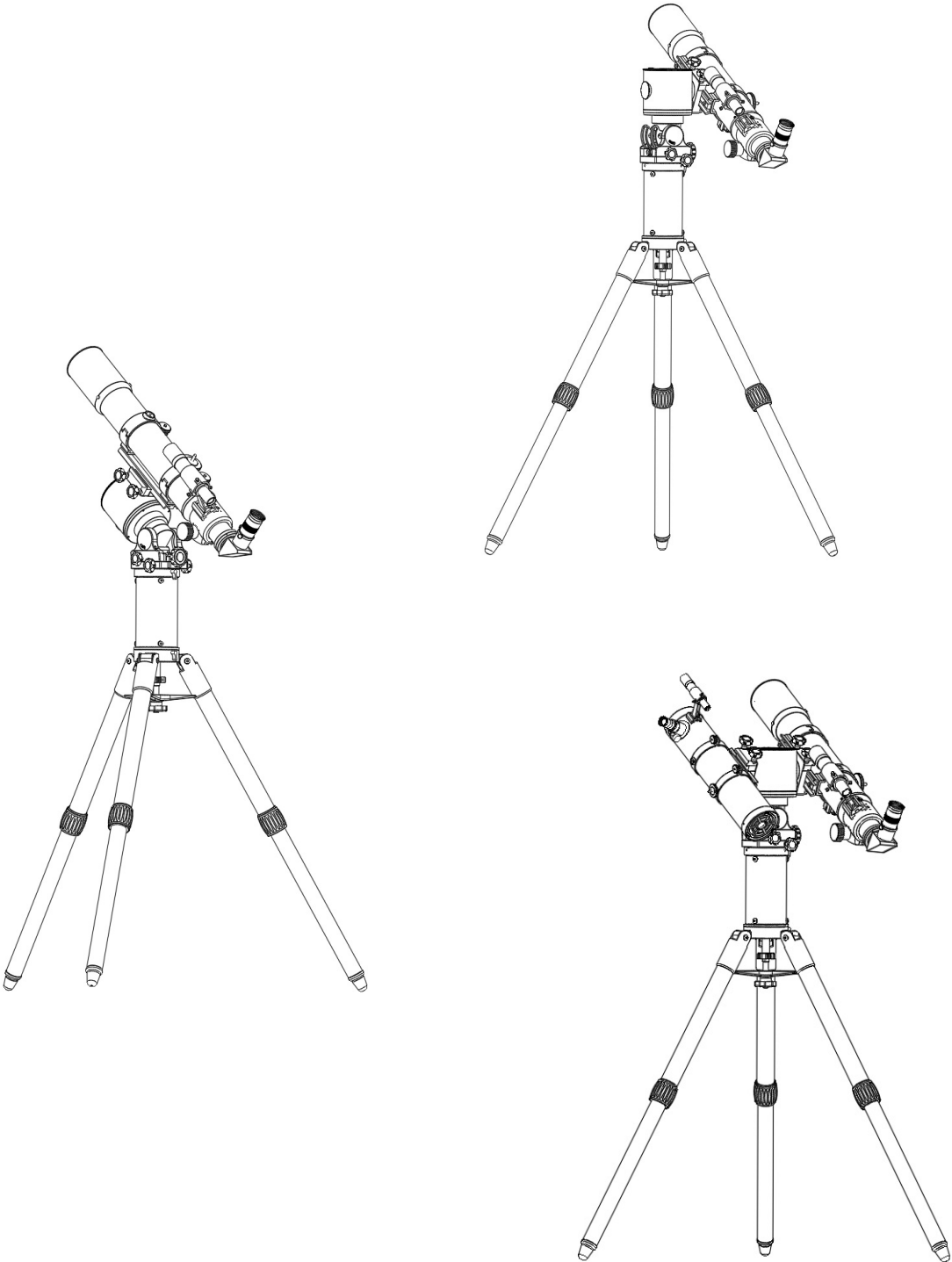

CONTENT

WAVE100i Mount Packing List

PART I:Installation

1.1 Setup Tripod and WAVE100i	4
1.2 Tilt Declination Axis	4
1.3 Install the telescope	5
1.4 Install counterweight.....	6
1.5 Balance the Payload.....	6
1.6 Install the second saddle(Alt-AZ mode).....	8

Part II:Polar alignment

2.1 General Process.....	9
2.2 Polar Alignment Based on Star Alignment.....	9
2.3 Polar Alignment Based on Imaging.....	9

Part III: Control Interfaces

3.1Control panel.....	10
3.2 Pinout of the Interfaces.....	11
3.3 Power Supply Requirements.....	11

Part IV: The WAVE 100i mount Features

4.1 SynScan Pro APP.....	12
4.2.SynScan Hand Controller.....	12
4.3 Auto-Home	12
4.4 Illumination	12
4.5 Firmware Update.....	12

APPENDIX:SPECIFICATIONS.....	13
-------------------------------------	-----------

WAVE100i mount Packing List

Mount Package Includes:

WAVE100i Mount x 1

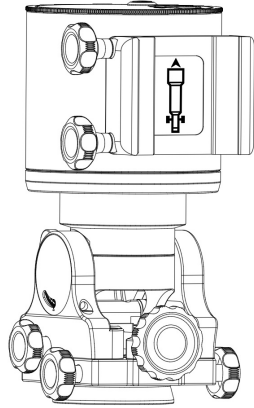

Saddle x 1

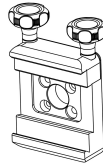

Saddle Cover x 1



3 mm Hex Key x 1

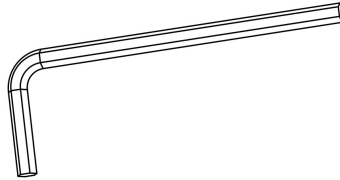

4mm Hex Key x 1

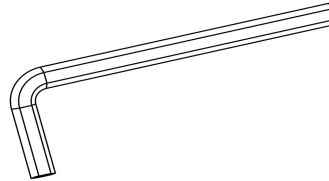

Screws M6 x 2

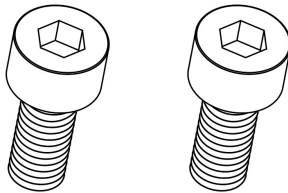

Screws M5 x 2

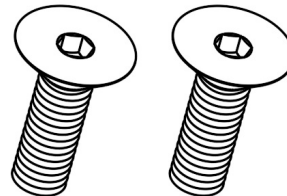

Power Cable x 1

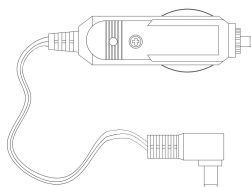

USB Cable x 1

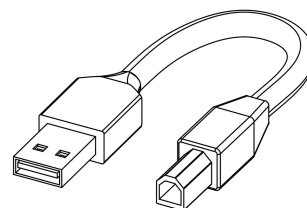

PART I: Installation

1.1 Setup Tripod and Wave 100i

The WAVE 100i mount can be installed on multiple tripods and extension stands, please refer to the instruction manual in you tripod kits for details. If the mount is going to be setup in the equatorial mode, make sure one of the tripod legs orient to the polar direction (**N**). While attaching the mount to the tripod, please align the R.A. axis to the north (or south, when observing in the southern hemisphere) orienting tripod leg.

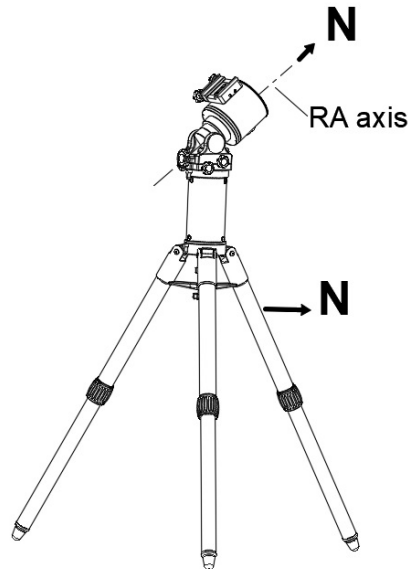

Fig. 1

1.2 Tilt Declination Axis

1. For use in equatorial (**EQ**) mode, loosen slightly the two Latitude locking knobs and turn the Latitude adjustment knob until the arrow on the latitude scale of the mount matches the latitude of your observing site. Lock the two Latitude locking knobs. (Fig.2)
2. For use in Alt-Azimuth (**AZ**) mode, rotate the Altitude adjustment knob until it stops turning and lock Latitude locking knobs. leave the mount in upright position as shown in Fig.3

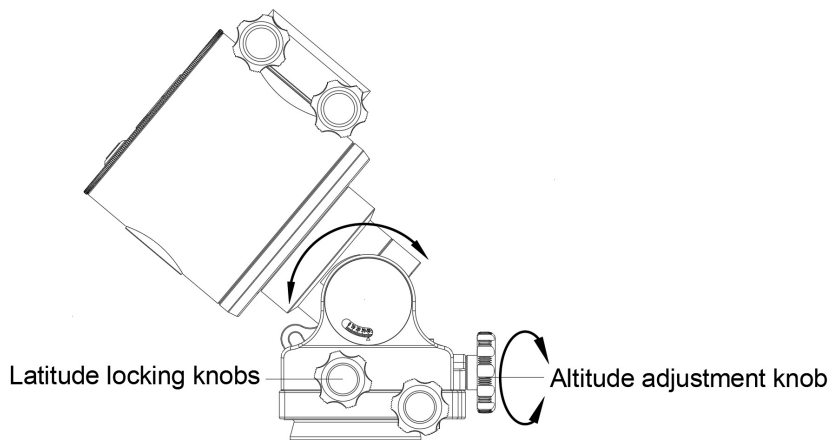

Fig. 2

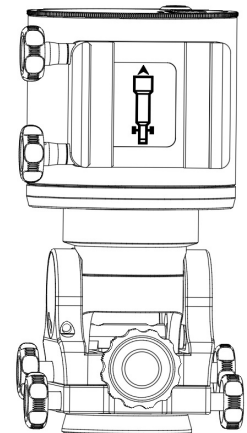

Fig. 3

1.3 Install the telescope

1. Turn on the power and connect the mount with Synscan pro App or hand control,
2. Use the direction buttons to slew the declination axis and level the groove with the telescope locking knobs on the upper side. (Fig 4a and Fig 5a)
3. Loosen the two telescope locking knobs on the saddle alternately until the width of groove is slightly wider than the width of the dovetail bar on the telescope.
4. Seat or slide the dovetail bar into the groove with the telescope pointing to the right. Tighten the two locking knobs alternately to secure the dovetail bar firmly (Fig. 4b and Fig. 5b).

Warning: Keep supporting the telescope until you are sure that it has been firmly locked in the groove.

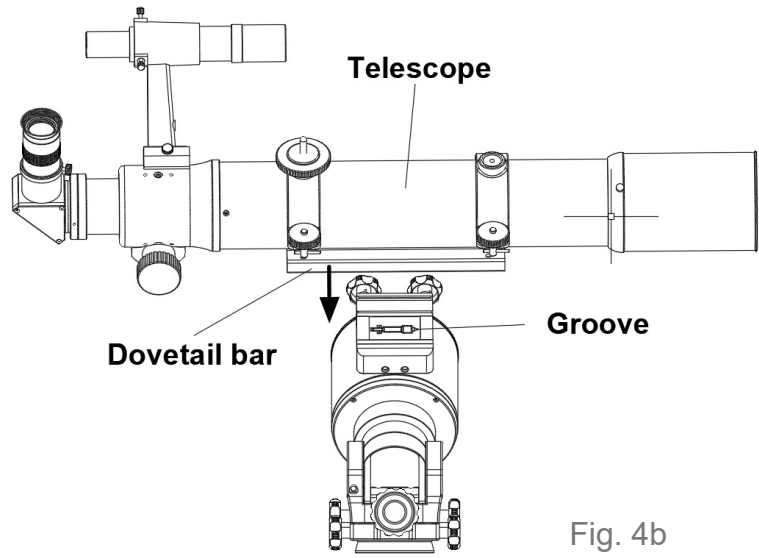
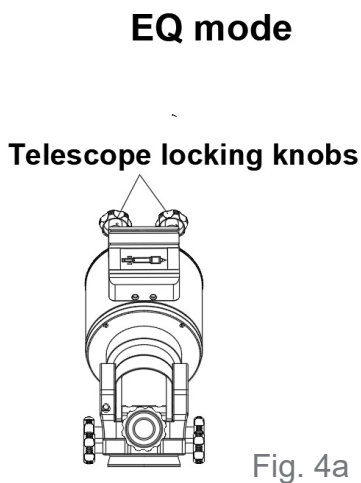

Fig. 4

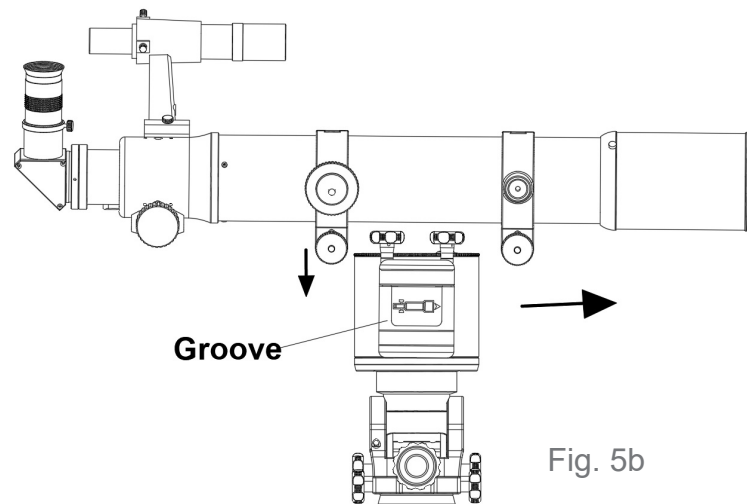

Fig. 5

1.4 Install counterweight

Counterweight is optional unless the telescope and accessories are very heavy.

1. Remove the cap on the mount and keep it in a safe place.
2. Thread in the counter weight rod, the long one, the short one or both if necessary. Turn clockwise to tighten.
3. Remove the security cap on the rod. Slide the counterweight onto the rod and tighten the locking knob. Thread in the security screw immediately.

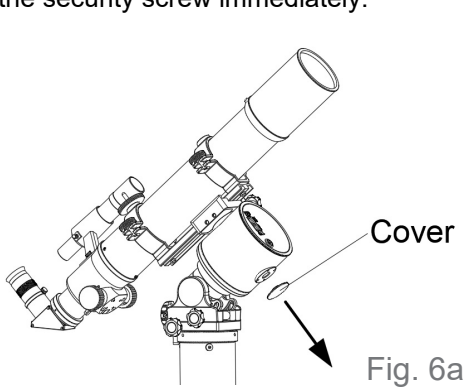

Fig. 6a

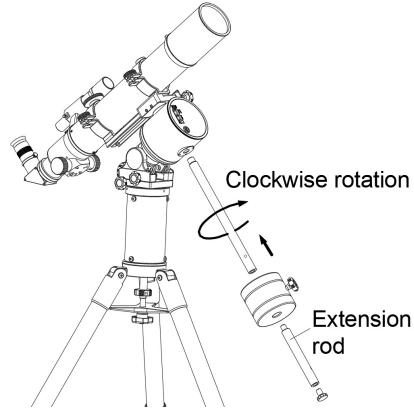

Fig. 6b

Fig. 6a

1.5 Balance of the Payload

The Wave 100i mount can support unbalanced payload in both R.A(Azimuth) and declination(Altitude) axis. But balancing(even partially) the payload can provide the following benefits:

- * Higher stability, especially when the supporting area of the tripod is small.
- * Less power consumption.
- * Higher tracking performance.

1.5.1 Balance in declination/altitude axis

- * Use the SynScan Pro app to slew the two axes and level the telescope with the telescope locking knobs on the upper side.(Fig.7)
- * Adjust the position of the telescope (by shifting the dovetail in the clamp or by shifting the telescope in the tube rings) to maintain balance of the telescope around the DEC axis(Fig.7~Fig.8)
- * For tube ring mounting, slide the telescope in the rings to obtain balance.
- * For non-tube ring mounting, keep holding the telescope, slightly loose the two telescope locking knobs and slide the dovetail bar in the groove to obtain balance and then firmly tighten the two telescope locking knobs.

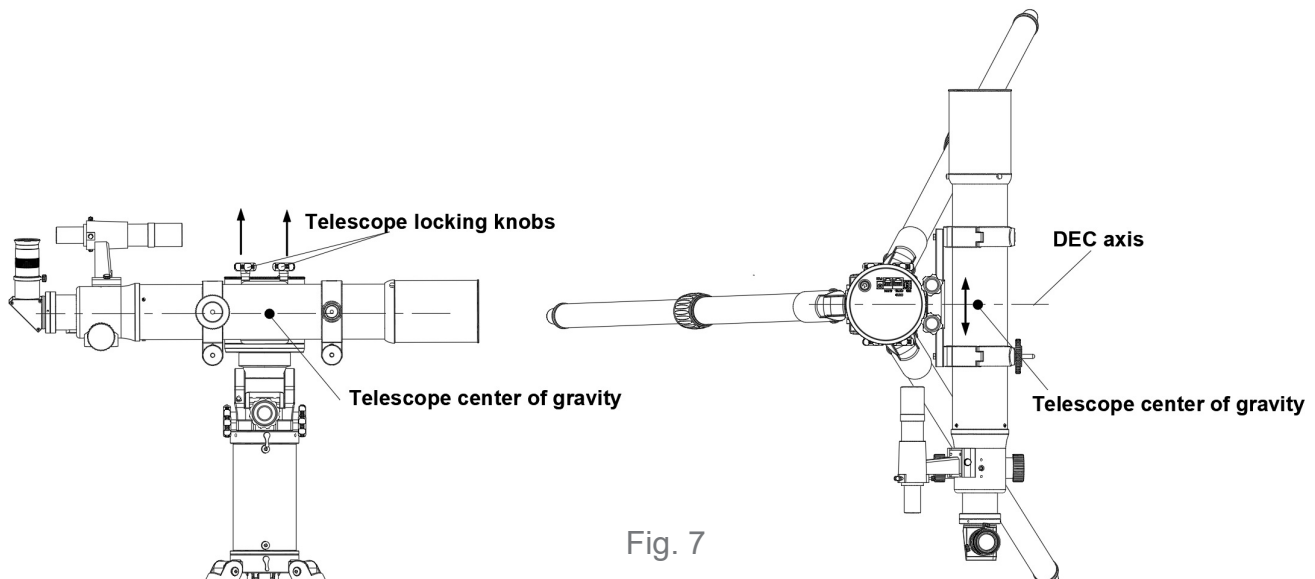

Fig. 7

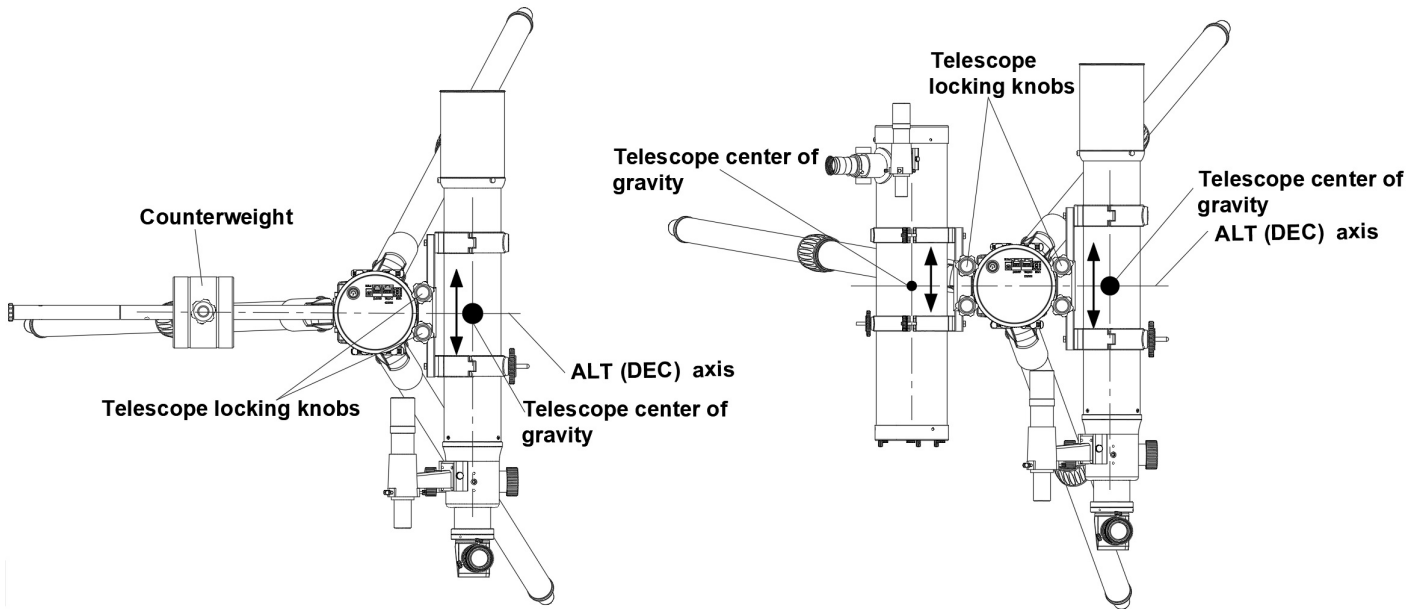
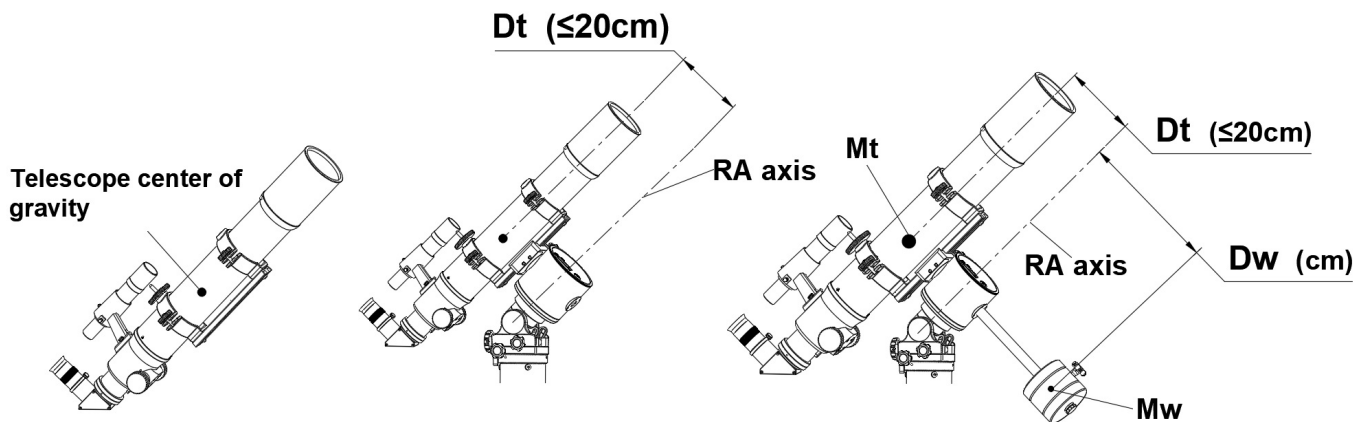

Fig. 8

1.5.2 Balance in Azimuth / R.A. axis

The RA axis needs balancing with heavy telescopes only. Telescopes with a weight below 10 kg do not need RA balancing.



Use the following formula to decide the counterweight's position:

$$Dw = Mt \times Dt / Mw$$

Mt: Mass of the telescope

Dt: Distance of the telescope's gravity centre to the axis.

Mw: Mass of the counterweight

Dw: Distance of the counterweight's gravity centre to the azimuth axis

Fig. 9

1.6 Install the second saddle(Alt-AZ mode)

1. Install the second saddle on the mount, and use a hex key to lock the saddle onto the mount with two allen countersunk screws M5 and two allen cylindrical head screws M6.
2. Install the cover plate on the saddle.

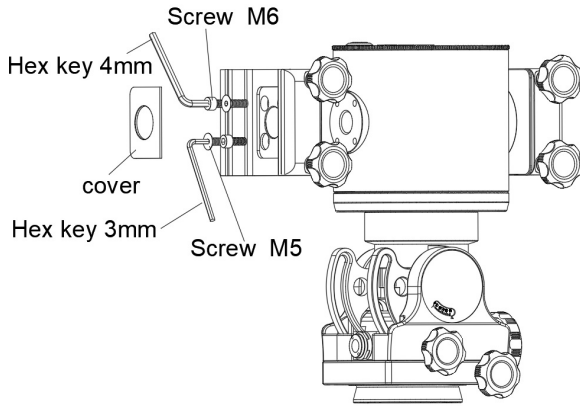

Fig. 10

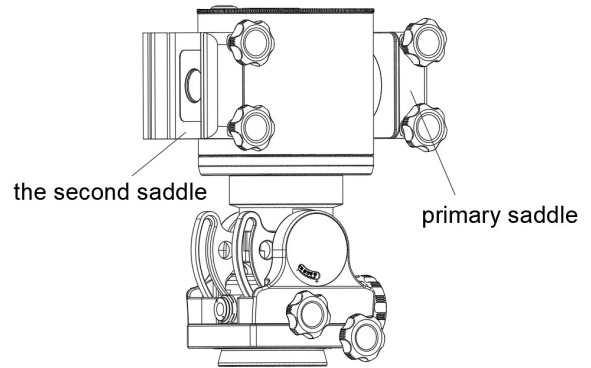

Fig. 11

Dual saddle adjustment

Use a 3mm hex key to adjust the screw M6 on the side of the primary saddle a few times, One is tightened and the other is loosened, ensuring that the two telescopes are aligned in the same direction and lock the two screws M6 .

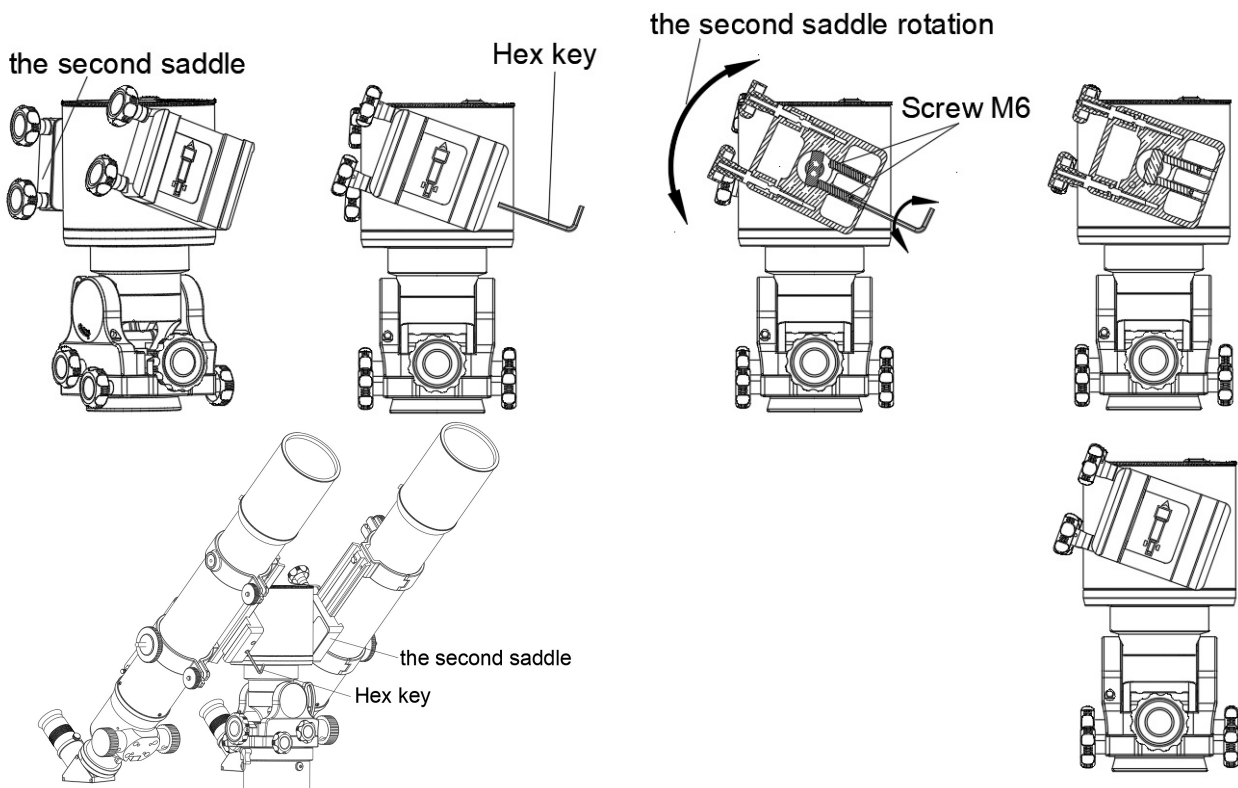
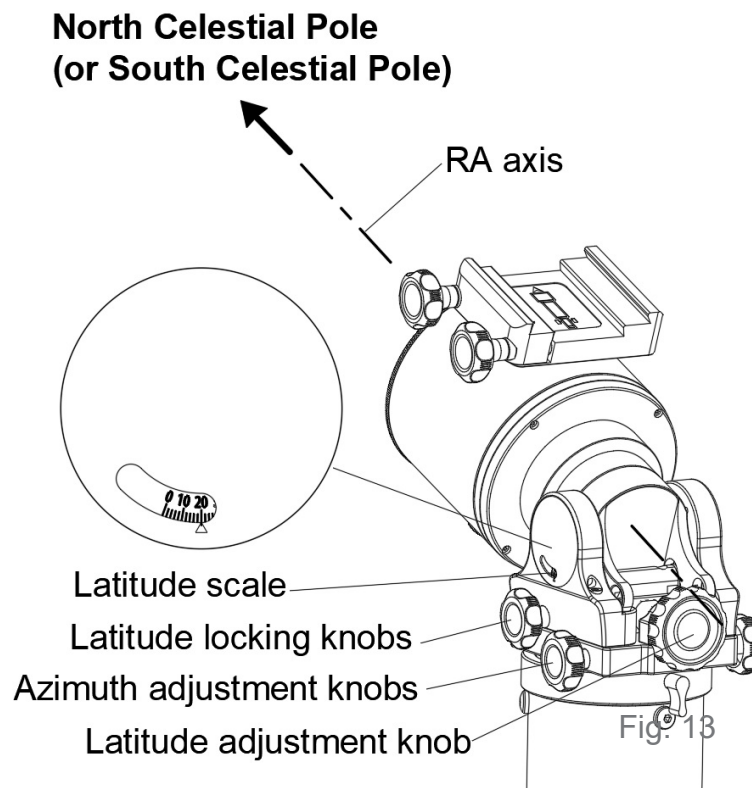

Fig. 12

Part II: Polar alignment of the WAVE100i Mount

2.1 General Process

1. Slightly loose the two Latitude Locking knobs.
2. Turn the Latitude Adjustment Knob to let the latitude scale read the local latitude.
3. Roughly point the RA axis to the pole.
4. Use one of the following means in section 2.2 or 2.3 to do the polar alignment.
5. Use the Latitude Adjustment knob to fine tune the tilt of the R.A. axis. Use the azimuth adjustment knobs to fine tune the horizontal direction of the R.A. axis towards the pole. Tighten the Latitude locking knobs and the Azimuth Adjustment Knobs at the end of the polar alignment.



2.2 Polar Alignment based on Star Alignment

1. Run a 2-Star alignment with the SynScan Pro app or the SynScan hand controller.
2. Run the polar alignment process.
3. Repeat the above steps for two or three times.

2.3 Polar Alignment based on Imaging

Many applications, like SharpCap Pro and PHD2, provide highly accurate, imaging based, polar alignment. Please refer to the instruction manual of those software for details.

Part III: Control Interfaces

3.1 Control Panel

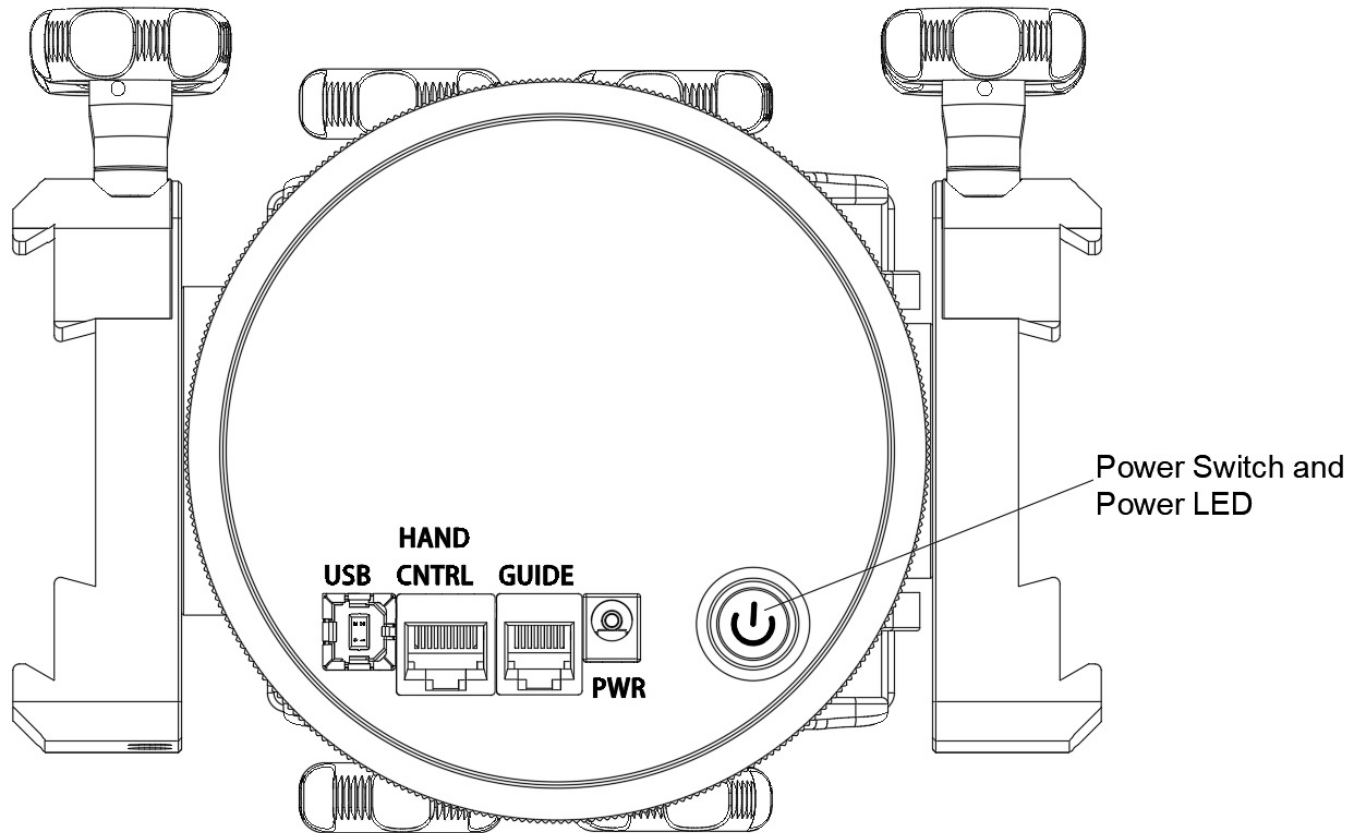

Fig. 14

Connectors to operate the Wave 100i mount:

PWR: Power supply Input.

USB: Communication port to connect to a computer or an Android device.

HAND CNTRL: Communication port to connect to a SynScan controller or other devices.

GUIDE: ST-4 autoguider port.

Power Switch: Turn power On/Off, with the light indicating the following status:

1. Single flashing with short On time: Wireless module is ready for connection.
2. Double flashing: Wireless connection established.
3. Steady On: Wireless module is turned off due to long idle.
4. Single slow flashing with equal on/off time: Power voltage is low.
5. Single quick flashing: Power voltage is extremely low, stop using the mount immediately.
6. Triple flashing: Firmware update is not finished.

3.2 Pinout of the Interfaces:

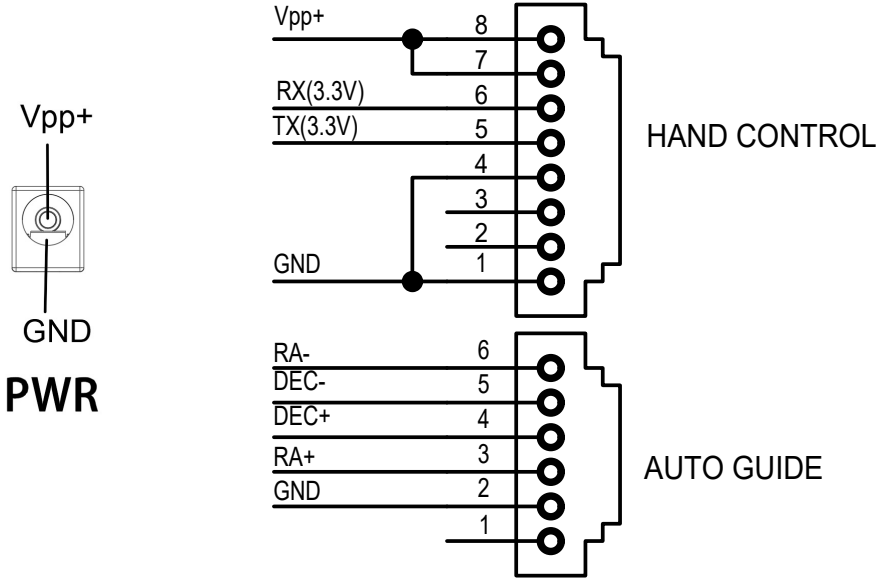

Fig. 15

3.3 Power Supply Requirements

- 1. Output Voltage: DC 12 to 16 V, higher voltage is recommended.
- 2. Power Rating: >35W (>3A @12VDC or >2.2A @16VDC)
- 3. Barrel Plug: 2.1mm I.D, 5.5mm O.D., central positive
- 4. Do not use an unregulated AC-to-DC adapter.

Part IV: The WAVE100i Mount Features

4.1 SynScan pro APP

SynScan Pro app is the recommended controller for the Wave 100i mount. Windows and Mac version: Download from www.skywatcher.com. Support USB, Wi-Fi, Bluetooth connections.

Android version: Download from Google Play or www.skywatcher.com. Support USB, Wi-Fi and Bluetooth connection. While using an USB connection with an Android device, a USB OTG dongle is required.

iOS version: Download from App Store. Support Wi-Fi, Bluetooth connections.

The SynScan Pro app can also work with a gamepad on all platforms. Please refer to the SynScan Pro app's inline help or instruction manual for details.

4.2 SynScan Hand Controller

SynScan hand controller is an optional controller for the Wave 100i mount. Please refer to the SynScan hand controller manual for detail instructions.

4.3 Auto-Home

The SynScan Pro app can return the mount to the same home position. Start the Auto-Home operation in SynScan Pro app's menu "Utility\Advanced\Auto Home"

* For equatorial mode: Fill the Dec Offset with 0, the mount will return to the polar-home position.

* For alt-az mode: Fill the Dec offset with -90, the mount will return to the north-level position.

NOTICE: Avoid starting Auto-Home in the following position: Dec/Alt=-90°/270°.

4.4 Illumination

The WAVE 100i has illuminated latitude scale and level bubble. The brightness can be adjusted using the Polar Scope Illuminator settings in the SynScan Pro app or the SynScan hand controller.

4.5 Firmware Update

Please visit www.skywatcher.com to check for the latest firmware for the Wave 100i mount. The firmware can be downloaded with the Motor Controller Firmware Loader application. Detail instruction is included in the application package.

APPENDIX: SPECIFICATIONS

Dimensions (mm)

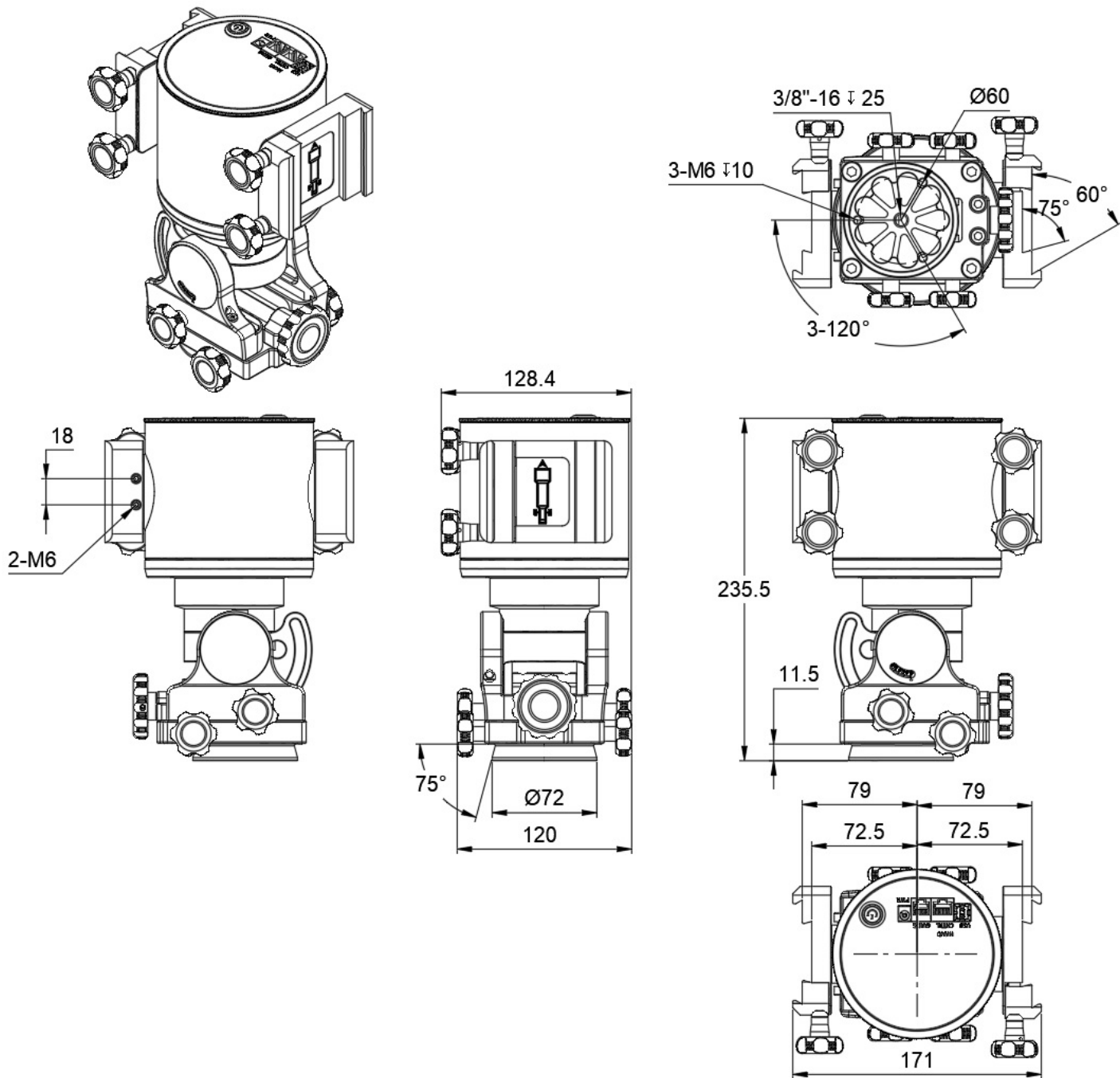

APPENDIX:SPECIFICATIONS

Specifications:

Product Name	WAVE100i mount
Mount Type	Equatorial /Alt-Az Dual Mode
Maximum Balanced Payload	3kgf·m (15kg @0.2m)
Maximum unbalanced in R.A.	2kgf·m (10kg @0.2m)
Maximum unbalanced in Declination/Altitude	0.45kgf·m (15kg @0.03m)
Polar Alignment Range	90 Degrees in Latitude, 20 Degrees in Azimuth
Weight	4.2kg
Counterweight (optional)	1x 5kg
Counterweight Rod (optional)	0.7kg+0.4kg
Extension pier (optional)	1kg
Motor Drive	Stepper Motor(1.8°/step), 256 Microsteps per step
Gear Ratio	RA: 324:1; DEC: 324:1
Power Supply	DC12V to 16V, >35W
Maximum Slewing Speed	7.5 degrees/second
Auto-guiding Speed	0.125X, 0.25X, 0.5X, 0.75X, 1X
GOTO Controller	SynScan Pro App or SynScan Hand Controller (Optional)
Operational Temperature	-10°C ~ 50°C
Celestial Object Catalog	Messier, NGC, IC, Caldwell, Double Star, Variable Star, Named Star, Planets
Telescope Mounting Bar	43mm~73mm dovetail bar

Note: The above specifications may be changed without advance notice.

WARRANTY & CUSTOMER SUPPORT

Warranty information differs from region to region. Contact your local dealer for the warranty in your region. Warranty shall be void and of no force of effect in the event a covered product has been modified in design or function, or subjected to abuse, misuse, mishandling or unauthorized repair. Further, product malfunction or deterioration due to normal wear is not covered by this warranty. Sky-Watcher is not responsible for any user modifications to any products.

Sky-Watcher reserves the right to modify or discontinue, without prior notice to you, any model or style telescope. For technical and customer support, you will need to contact your regional support team. Please refer to the Sky-Watcher website and check under "Global Distributer" for your specific region.

<http://www.skywatcher.com/where-to-buy/>

WAVE100i Mount



NEVER USE YOUR TELESCOPE TO LOOK DIRECTLY AT THE SUN. PERMANENT EYE DAMAGE WILL RESULT. USE A PROPER SOLAR FILTER FIRMLY MOUNTED ON THE FRONT OF THE TELESCOPE FOR VIEWING THE SUN. WHEN OBSERVING THE SUN, PLACE A DUST CAP OVER YOUR FINDERSCOPE OR REMOVE IT TO PROTECT YOU FROM ACCIDENTAL EXPOSURE. NEVER USE AN EYEPIECE-TYPE SOLAR FILTER AND NEVER USE YOUR TELESCOPE TO PROJECT SUNLIGHT ONTO ANOTHER SURFACE, THE INTERNAL HEAT BUILD-UP WILL DAMAGE THE TELESCOPE OPTICAL ELEMENTS.