

INSTRUCTION MANUAL

GSO – DOBSONIANS

D – 304mm/1520mm

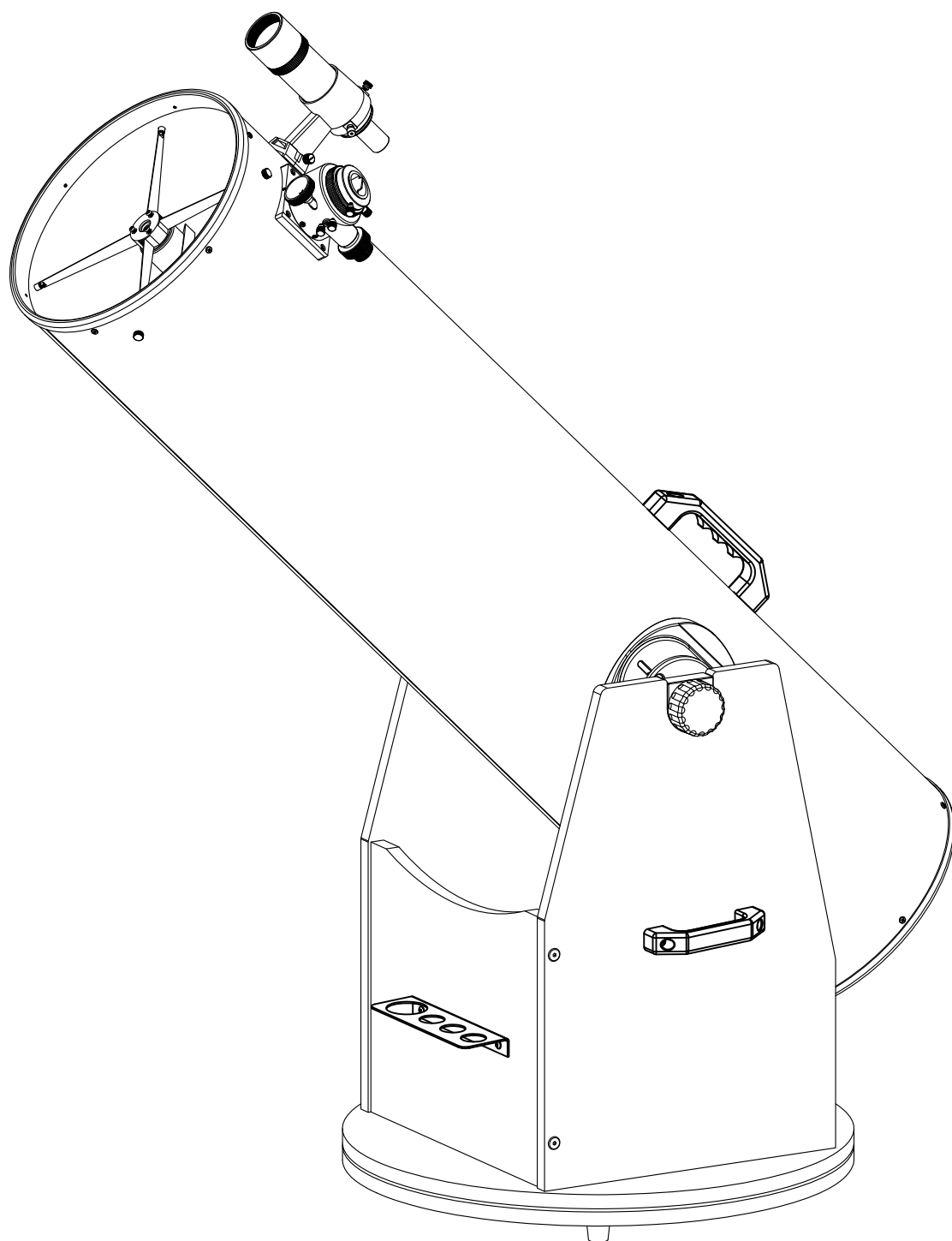

PART LIST

1. Wood Base

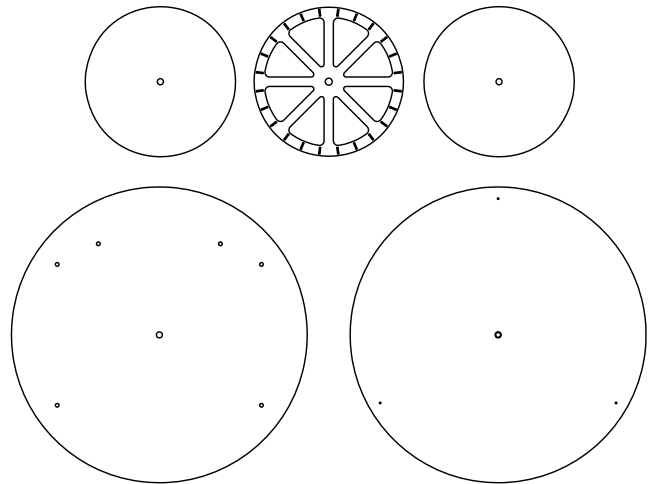
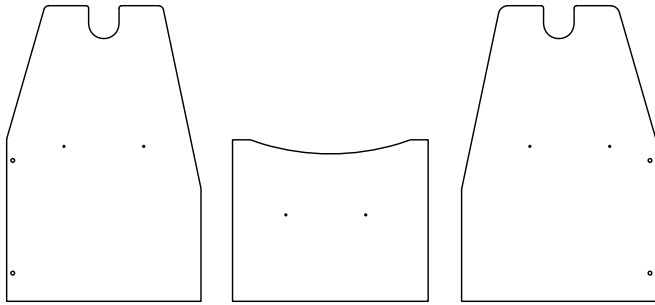

2. Screw parts list

Self-tapping wood screw x10

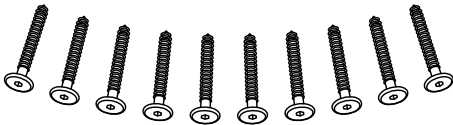

5/16-18 adjustment bolt x1, 8mm/16mm washer x1,
Roller bearing 8.5mm x 15mm x1,
Center bearing bushing x1, 12.9mm/25mm washer x1

Eyepieces holder x1, Self-tapping wood screw x2

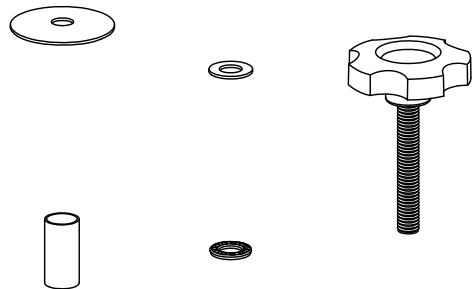
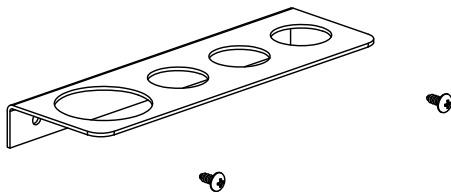

Plastic Feet x3, Self-tapping wood screw x3

Plastic handle x2, 1/4-20 1-1/4" Screw x4

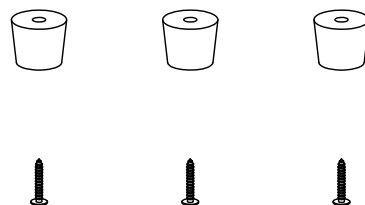
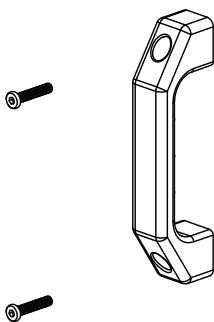

WOOD BASE ASSEMBLY

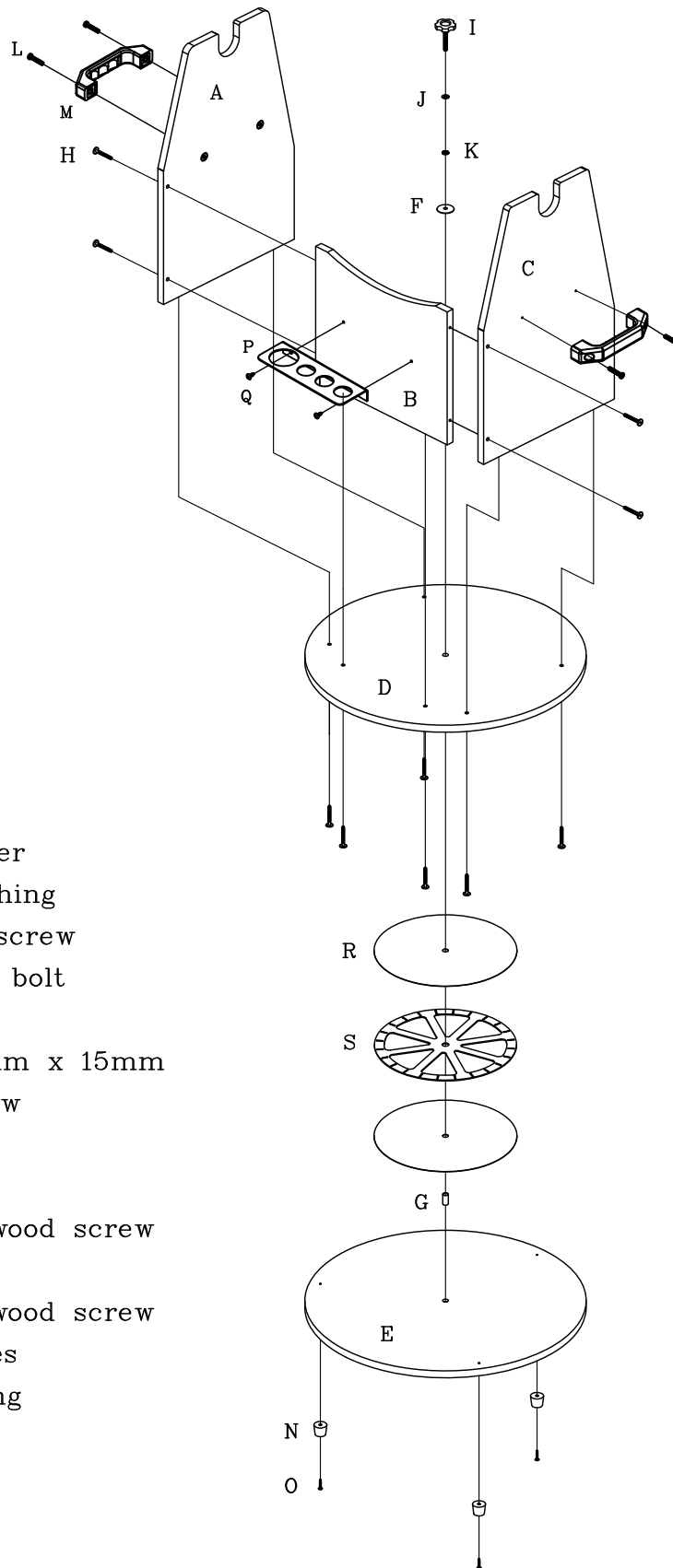

12" Dobsonian

A=Side Panels

B=Front Brace

C=Side Panels

D=Top Base plate

E=Ground Base plate

F=8.2mm/38mm Washer

G=Center bearing bushing

H=Self-tapping wood screw

I=5/16-18 adjustment bolt

J=8mm/16mm Washer

K=Roller bearing 8.5mm x 15mm

L=1/4-20 1-1/4" Screw

M=Plastic Handle

N=Plastic Feet

O=3/16 Self-tapping wood screw

P=Eyepieces holder

Q=3/16 Self-tapping wood screw

R=Roller bearing plates

S=Plastic roller bearing

OPTICAL TUBE ASSEMBLY

Place the optical tube on the wood base.

Complete assembly of OTA and base.

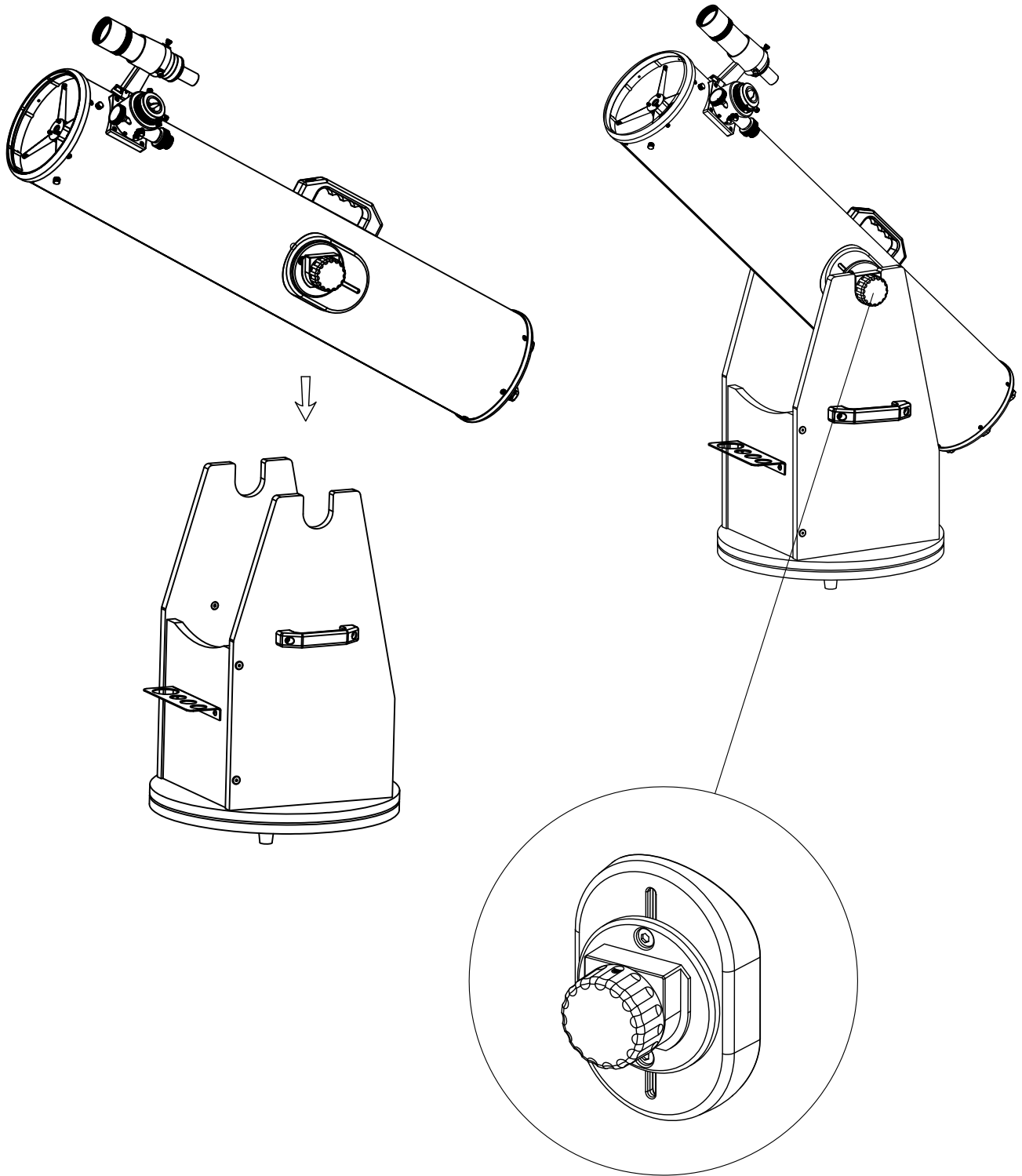

OPTICAL TUBE ASSEMBLY

1. OTA (Optical Tube Assembly)

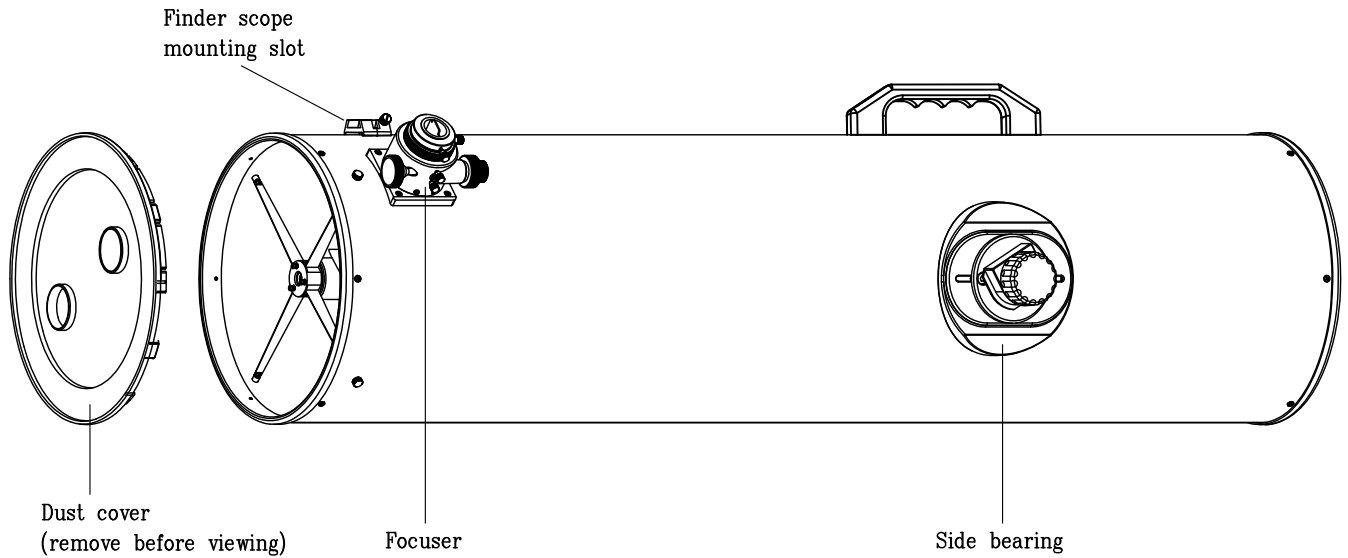

Locate the finder scope bracket and remove the rubber-o-ring on it. Position the o-ring into groove on the finder scope tube.

Slide the finder scope bracket into the mounting slot and tighten the screw to hold the bracket in place.

Loosen the two plastic adjusting screws on the bracket. Position the finder scope into the bracket by sliding it backwards until the rubber o-ring seats.

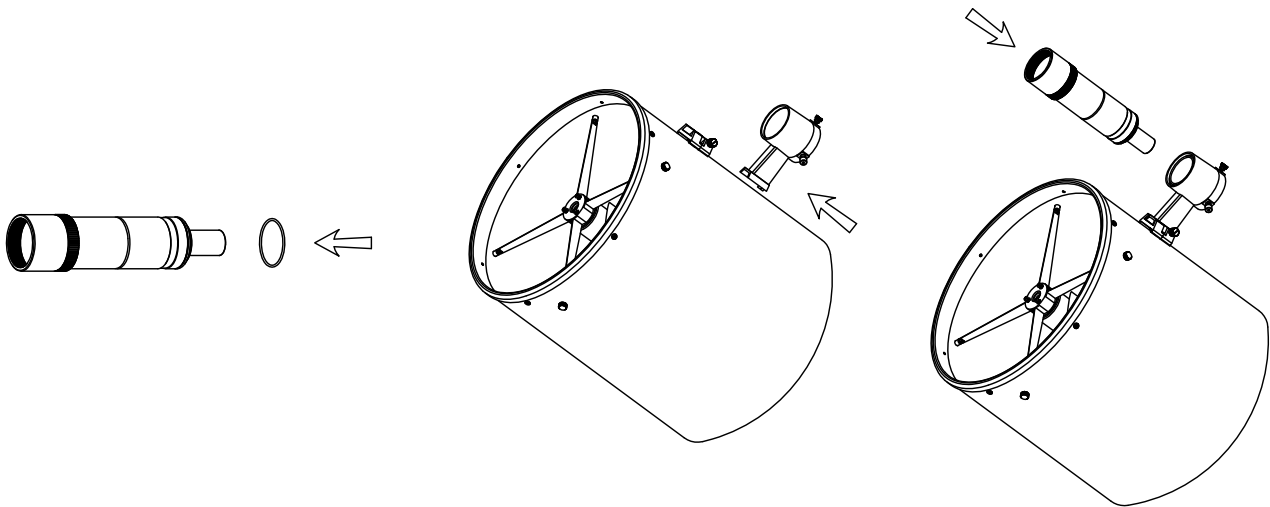

remove the dust cover and Loosen the thumbscrews on the end of the focuser adapter.

Insert the 1.25" or 2" eyepiece and lightly tighten the thumbscrews to hold the eyepiece in place.

